

Model: VGA-018F

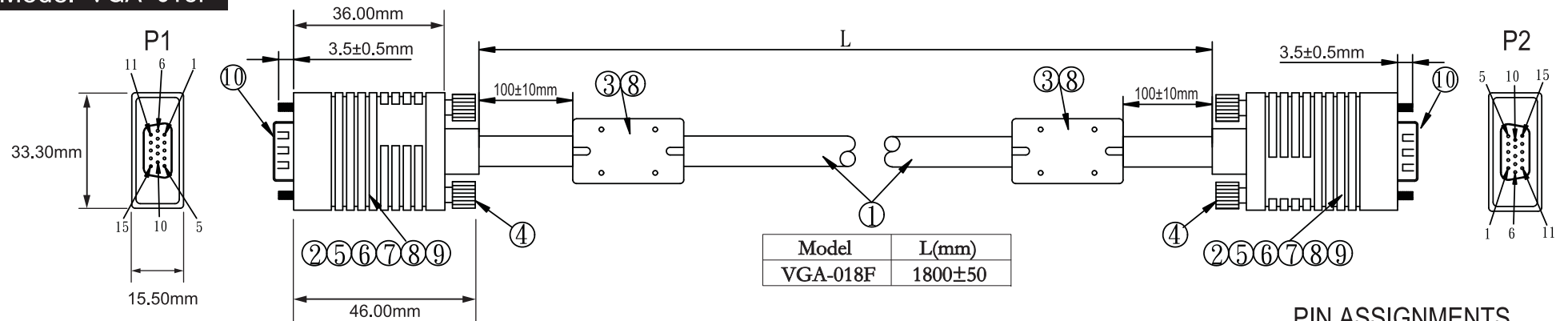

Model	L(mm)
VGA-018F	1800±50

PIN ASSIGNMENTS

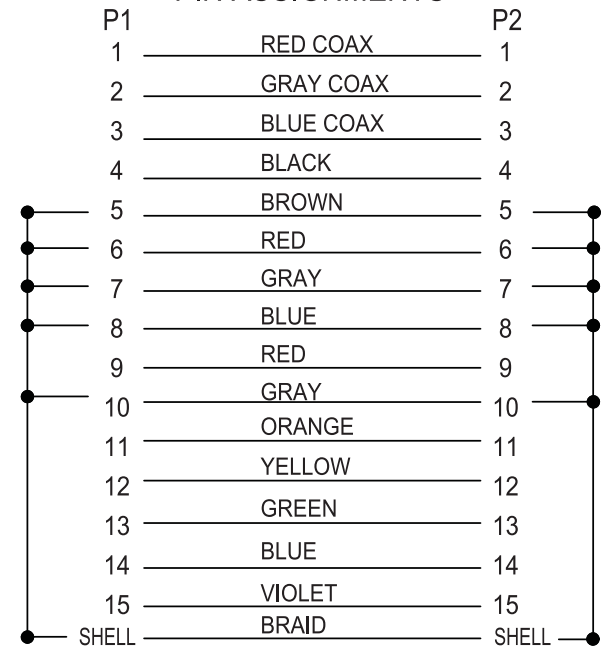

NOTES :

- 100% OPEN, SHORT & MISWIRE TEST.
- PAY ATTENTION TO PIN ASSIGNMENTS

NO	DESCRIPTION		QTY
1	CABLE	UL/CSA 20276(30AWG* 1C+EA)*3+30AWG*9C+AB 65% OD : 6.0mm COLOR : BLACK CLR-006	1
2	CONNECTOR	HDD 15P MALE PIN G/F SHELL TIN PLATED PBT:BLUE	2
3	CORE	CORE B29 OD 14.2*L28.5*ID27.2mm	2
4	SCREW	SCREW 4.5*40.5mm #4-40 BLACK NICKLE PLATED ABS : BLACK	4
5	TUBE	UL/CSA 125°C VW-1(F4) 300V φ 1.5mm BLACK	2
6	COPPER FOIL	W30*T0.04mm	2
7	JUMP WIRE	UL/CSA 1061 26AWG COLOR : BLUE	2
8	PVC	PVC SHORE A 88±2 COLOR : BLACK	2
9	PE	PE CLEAR	2
10	DUST COVER	PE CLEAR	2

COMPONENT NO : FULLnVGA 1.8/5/20M	DVS Corporation		
APPROVED :			
CHECKED :	Model:VGA-018F		
DRAWN : 熊景	REQUIRED DOCUMENTS : *		
DATE : 7-10-10	SCALE : 1/1	SHEET : 1/1	REV : 1
FILE : F:\DWG\BJ8804A.DWG	DRAWING : TJA06027	THIRD ANGLE PROJECTION	